



Designation: D924 – 23

# Standard Test Method for Dissipation Factor (or Power Factor) and Relative Permittivity (Dielectric Constant) of Electrical Insulating Liquids<sup>1</sup>

This standard is issued under the fixed designation D924; the number immediately following the designation indicates the year of original adoption or, in the case of revision, the year of last revision. A number in parentheses indicates the year of last reapproval. A superscript epsilon ( $\epsilon$ ) indicates an editorial change since the last revision or reapproval.

*This standard has been approved for use by agencies of the U.S. Department of Defense.*

## 1. Scope

1.1 This test method describes testing of new electrical insulating liquids as well as liquids in service or subsequent to service in cables, transformers, oil circuit breakers, and other electrical apparatus.

1.2 This test method provides a procedure for making referee tests at a commercial frequency of between 45 Hz and 65 Hz.

1.3 Where it is desired to make routine determinations requiring less accuracy, certain modifications to this test method are permitted as described in Sections 16 to 24.

1.4 The values stated in SI units are to be regarded as standard. No other units of measurement are included in this standard.

1.5 *This standard does not purport to address all of the safety concerns, if any, associated with its use. It is the responsibility of the user of this standard to establish appropriate safety, health, and environmental practices and to determine the applicability of regulatory limitations prior to use.* Specific warnings are given in 11.3.3.

1.6 *Mercury has been designated by the EPA and many state agencies as a hazardous material that can cause nervous system, kidney and liver damage. Mercury, or its vapor, may be hazardous to health and corrosive to materials. Caution should be taken when handling mercury and mercury containing products. See the applicable product Safety Data Sheet (SDS) for details and the EPA's website for additional information. Users should be aware that selling mercury and/or mercury containing products into your state may be prohibited by state law.*

1.7 *This international standard was developed in accordance with internationally recognized principles on standard-*

*ization established in the Decision on Principles for the Development of International Standards, Guides and Recommendations issued by the World Trade Organization Technical Barriers to Trade (TBT) Committee.*

## 2. Referenced Documents

### 2.1 ASTM Standards:<sup>2</sup>

**D150** Test Methods for AC Loss Characteristics and Permittivity (Dielectric Constant) of Solid Electrical Insulation  
**D923** Practices for Sampling Electrical Insulating Liquids  
**D2864** Terminology Relating to Electrical Insulating Liquids and Gases

**D2865** Practice for Calibration of Standards and Equipment for Electrical Insulating Materials Testing  
**E691** Practice for Conducting an Interlaboratory Study to Determine the Precision of a Test Method

### 2.2 IEEE Standard:<sup>3</sup>

**Standard 4** IEEE Standard Techniques for High-Voltage Testing

## 3. Terminology

3.1 *Definitions*—Definitions of terms used in this test method are given in Terminology **D2864**. Also refer to Test Methods **D150** for detailed discussion of terms.

## 4. Significance and Use

4.1 *Dissipation Factor (or Power Factor)*—This is a measure of the dielectric losses in an electrical insulating liquid when used in an alternating electric field and of the energy dissipated as heat. A low dissipation factor or power factor indicates low ac dielectric losses. Dissipation factor or power factor may be useful as a means of quality control, and as an

<sup>1</sup> This test method is under the jurisdiction of ASTM Committee **D27** on Electrical Insulating Liquids and Gases and is the direct responsibility of Subcommittee **D27.05** on Electrical Test.

Current edition approved Dec. 1, 2023. Published December 2023. Originally approved in 1947 as D924–47 T. Last previous edition approved in 2015 as D924–15. DOI: 10.1520/D0924-23.

<sup>2</sup> For referenced ASTM standards, visit the ASTM website, [www.astm.org](http://www.astm.org), or contact ASTM Customer Service at [service@astm.org](mailto:service@astm.org). For Annual Book of ASTM Standards volume information, refer to the standard's Document Summary page on the ASTM website.

<sup>3</sup> Available from Institute of Electrical and Electronic Engineers, 445 Hoes Lane, Piscataway, NJ 08854, [www.ieee.org](http://www.ieee.org).

indication of changes in quality resulting from contamination and deterioration in service or as a result of handling.

4.1.1 The loss characteristic is commonly measured in terms of dissipation factor (tangent of the loss angle) or of power factor (sine of the loss angle) and may be expressed as a decimal value or as a percentage. For decimal values up to 0.05, dissipation factor and power factor values are equal to each other within about one part in one thousand. In general, since the dissipation factor or power factor of insulating oils in good condition have decimal values below 0.005, the two measurements (terms) may be considered interchangeable.

4.1.2 The exact relationship between dissipation factor ( $D$ ) and power factor ( $PF$ ) is given by the following equations:

$$PF = \frac{D}{\sqrt{1+D^2}} \quad D = \frac{PF}{\sqrt{1-(PF)^2}} \quad (1)$$

The reported value of  $D$  or  $PF$  may be expressed as a decimal value or as a percentage. For example:

$$D \text{ or } PF \text{ at } 25^\circ C = 0.002 \text{ or } 0.2\% \quad (2)$$

4.2 *Relative Permittivity (Dielectric Constant)*—Insulating liquids are used in general either to insulate components of an electrical network from each other and from ground, alone or in combination with solid insulating materials, or to function as the dielectric of a capacitor. For the first use, a low value of relative permittivity is often desirable in order to have the capacitance be as small as possible, consistent with acceptable chemical and heat transfer properties. However, an intermediate value of relative permittivity may sometimes be advantageous in achieving a better voltage distribution of ac electric fields between the liquid and solid insulating materials with which the liquid may be in series. When used as the dielectric in a capacitor, it is desirable to have a higher value of relative permittivity so the physical size of the capacitor may be as small as possible.

4.3 Theory relating to dielectric measurement techniques and to sources of dielectric loss is given in Test Methods **D150**.

## 5. Sampling

5.1 Sample electrical insulating liquids in accordance with Practices **D923**. Samples to be subjected to this test should preferably be obtained through a closed system. If exposed to atmospheric conditions, it is preferable to take the sample when the relative humidity is 50 % or less. If it is not feasible, the length of time the sample is exposed to atmospheric conditions must be kept to a minimum.

5.2 Some liquids, in certain applications, require special handling and processes in the sampling, and these will be found in the governing procedures. Consult such procedures before samples are taken.

5.3 The quantity of sample taken for this test shall be sufficient for at least three separate determinations of loss characteristics and relative permittivity.

5.4 The loss characteristic measurement (dissipation factor or power factor) may be affected by contamination introduced during sampling and subsequent handling.

## PROCEDURE FOR MAKING REFEREE TESTS

### 6. Apparatus

6.1 Measuring equipment used in these procedures shall be in accordance with Test Methods **D150**.

6.2 Use only a three-terminal cell for these tests.

6.3 The design of test cells that conform to the general requirements given in the Annex are considered suitable for use in making these tests.

6.4 *Forced-Draft Oven:*

6.4.1 When the tests are to be made above room temperature, a suitable forced-draft, thermostatically controlled oven shall be used as the test chamber. The oven must be capable of meeting the temperature requirements set out in Section **11**. For tests at room temperature the unheated oven can be conveniently used as the test chamber.

6.4.2 Provide the test chamber with an opening in the wall through which two lengths of TFE-fluorocarbon-insulated (or similar) shielded cable pass to make electrical connection from the measuring equipment and high-voltage transformer, respectively, to the test cell. Use a perforated ceramic plate or disk to insulate the test cell from the metal flooring of the oven if the flooring is not insulated from the oven. Provide a safety interlock on the door of the oven so that the electrical circuit supplying voltage to the test cell will be broken when the oven door is opened.

6.4.3 A cross-sectional view of the test chamber with a three-electrode test cell in place and with test cables connected is shown in **Fig. 1**.

6.5 *Automatic Thermo-Regulator Cell:*

6.5.1 When tests are to be made above room temperature but below the flash point, an automatic thermo-regulator cell can be used as long as it provides uniform heating of the test cell.

6.5.2 The automatic thermo-regulator cell must be able to provide rapid, controlled rate of temperature rise, and be able to maintain a liquid temperature constant to within  $\pm 1^\circ C$ .

### 7. Calibration

7.1 Calibration of test instruments shall be traceable to national standards.

7.2 Verify the calibration at least annually using reference devices that are traceable to national standards.

7.3 Refer to Practice **D2865** and IEEE Standard 4 for guidelines on calibrating test equipment.

### 8. Test Temperature

8.1 The temperature at which a referee test is made shall be mutually agreed upon between the purchaser and the seller. Measurements are made at many different temperatures. For acceptance tests, it is generally made at a temperature of  $100^\circ C$ , while for routine testing it is usually made at  $25^\circ C$ ,  $90^\circ C$ , or  $100^\circ C$ . In some research investigations, tests may be made at considerably higher temperatures while in other cases, particularly for tests on cable oils in service, tests may be made over a range of temperatures.

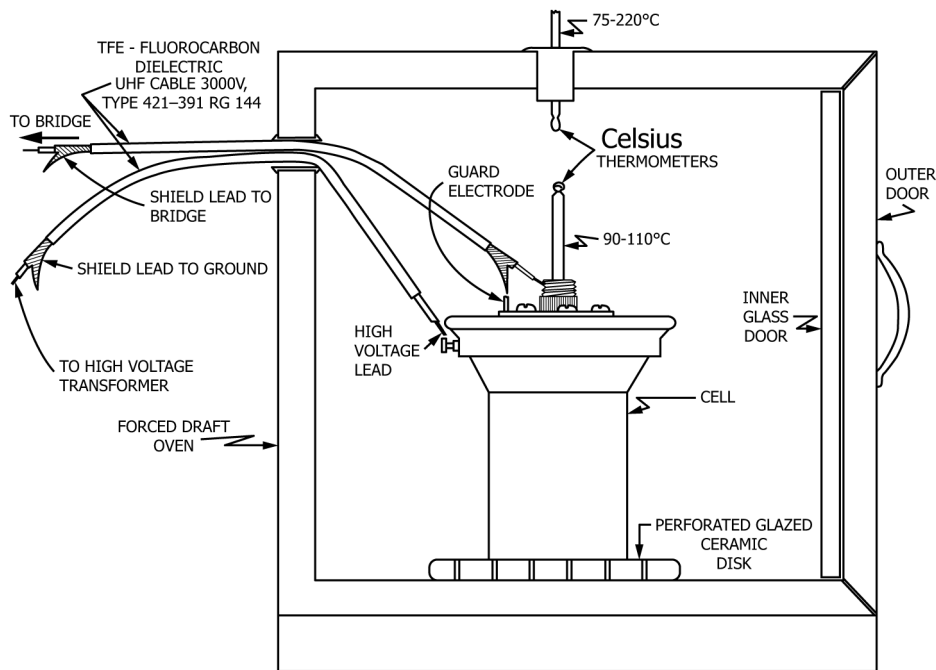

FIG. 1 Test Set-Up for Dissipation Factor Measurements at Elevated Temperatures Using Three-Electrode Test Cell

## 9. Test Voltage

9.1 The average stress to which the specimen is subjected shall not be less than 200 V/mm (5 V/mil) (rms). Tests at higher stresses are desirable but shall not reach such values that electrical discharges across the cell insulating surfaces occur or that internal ionization of the specimen may be expected. Stress ranges in normal usage for referee tests are 200 V/mm to 1200 V/mm (5 V/mil to 30 V/mil) (rms).

9.2 Because the ac loss characteristics can vary with voltage stress, for reference purposes it is desirable to make the measurements at a specific value of voltage stress within the limits in 9.1.

9.3 Referee tests should be carried out in the frequency range 45 Hz to 65 Hz.

## 10. Cleaning Test Cell

10.1 The cleanliness of the test cell is of paramount importance when measuring loss characteristics because of the inherent susceptibility of most insulating liquids to contaminating influences of the most minute nature. For this reason, clean and dry the cell immediately prior to making the test, and strictly observe the procedures and precautions outlined in 10.2 to 10.5.

10.2 Dismantle the cell completely and wash all the component parts thoroughly with a technical grade of a suitable solvent (such as acetone, pentane, petroleum ether, or heptane). Wash the component parts with a mild abrasive soap or detergent. Take care not to lay the electrodes on any surface. Rinse all parts thoroughly with hot tap water, then with cold tap water, followed by several rinses with distilled water. Take extreme care during the washing and rinsing of some test cells to prevent any moisture from entering the thermometer well in

the inner electrode. As a precaution against this eventuality, use a suitable stopper to plug this opening prior to starting the cleaning operation.

10.3 After the surfaces of the measuring, guard, and high voltage electrodes have been washed, do not touch these surfaces during the rinsing or any subsequent operation.

10.4 Place the component parts of the test cell in an oven maintained at 110 °C for a period of not less than 60 min. Do not dry test cells made of Monel at this elevated temperature for more than 90 min as oxidation will take place causing erroneous results. Take care that the surfaces on which the component parts of the cell are placed in the oven are clean.

10.5 At the expiration of the drying period, assemble the cell using clean cotton gloves as protection for the hands and to prevent contamination from skin oils and salt.

## 11. Preparation of Specimen and Filling Test Cell

11.1 Store the sample in its original sealed container, shielded from light. Some liquids, such as oils of petroleum origin, undergo changes when exposed to sunlight. Allow the sealed container to stand undisturbed in the room in which the test is to be made for a sufficient period of time to permit the sample to attain room temperature before it is opened.

11.2 When insulating liquids are heated to elevated temperatures, some of their characteristics undergo a change with time and the change, even though of the minutest nature, may be reflected in the loss measurement. It is therefore desirable that the elapsed time necessary for the test specimen to attain temperature equilibrium with the test cell be held to a minimum. For optimum procedure do not exceed 20 min for this time. It is essential, therefore, that the procedures outlined below be closely followed.